

7 STEELWORK CONNECTIONS

STRUTFAST

Floor Fixings

lindapter[®]

TYPE FF - Floorfast[®] HOT DIP GALVANISED

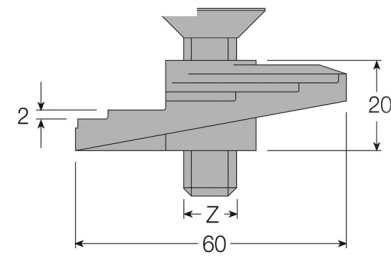
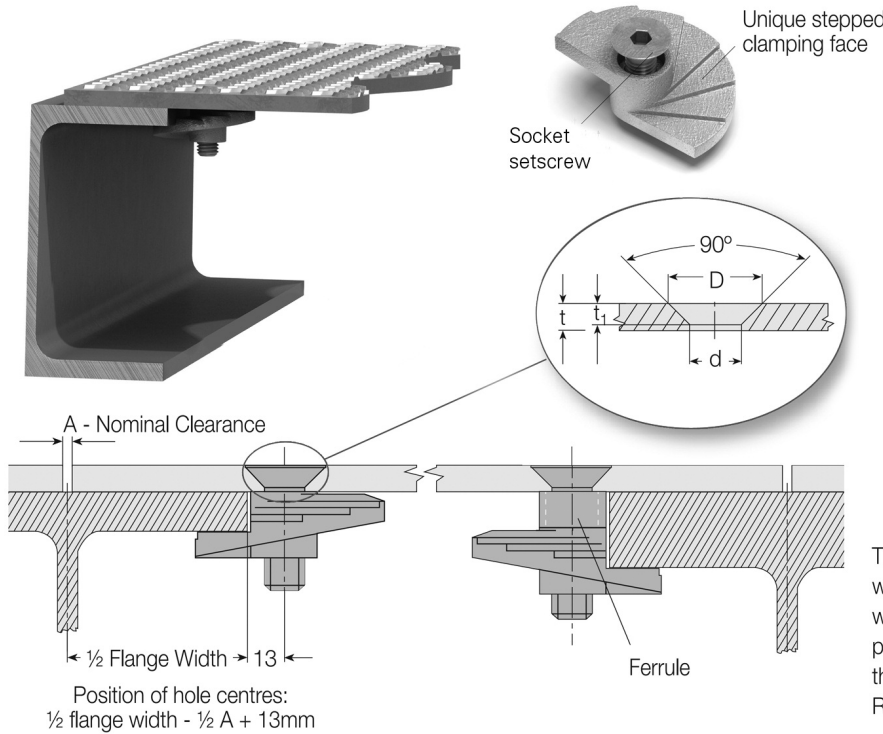

The product consists of a malleable iron body casting with a countersunk socket screw. The eccentric stepped web of the casting allows it to lock under the steel, providing full face contact when torque is applied. For thicker flanges, packing pieces can be supplied. Lloyd's Register Type Approval for vibration resistance.

Product Code	Bolt ¹⁾ Z	Floorplate Thickness t mm	Flange Thickness mm	Hole Ø d mm	Countersunk				Tightening Torque Nm	Hexagon Key mm
					Countersunk Ø for Bolt		Depth for Bolt	Tightening Torque		
					BZP	HDG				
FF10	M10	5 - 12	3 - 15	11	21	19	5	4	22	6
FF12	M12	6 - 12	3 - 15	13.5	25	23	5.8	4.8	22	8

1) In hot dip galvanised (M10 and M12) a slotted countersunk screw is supplied.

■ Order example: FF12 HDG

Installation

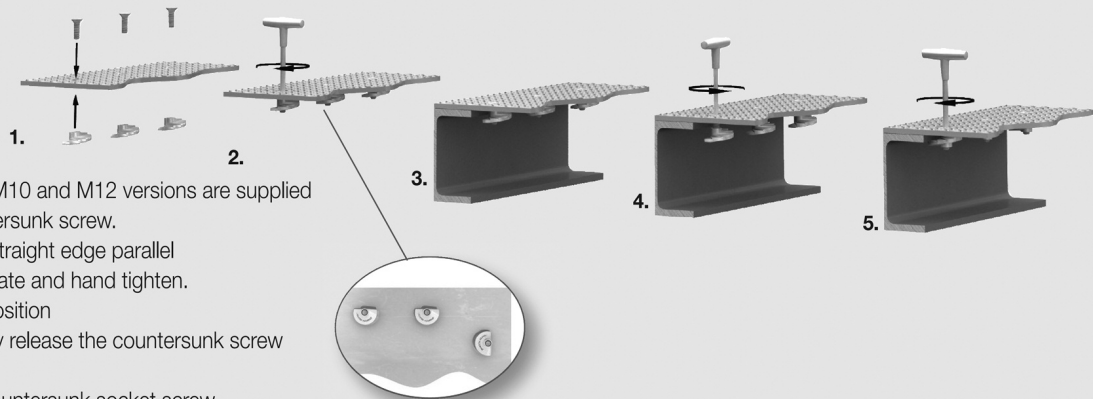

- Hot-dip galvanised M10 and M12 versions are supplied with a slotted countersunk screw.
- Align castings with straight edge parallel to the edge of the plate and hand tighten.
- Lay floorplate into position
- Using a hexagon key release the countersunk screw one full turn.
- Tighten down the countersunk socket screw.

Removal

Using a hexagon key, give the Type FF one full anticlockwise turn to release connection from the flange.